

# KJK<sup>®</sup>

## KJK228 Wi-Fi Trail Camera

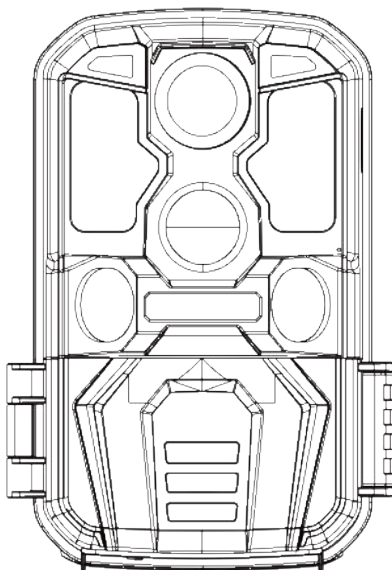

## User Manual

V23121301

## TABLE OF CONTENT

|  |       |
|--|-------|
| <b>1. IN THE BOX</b>                           | 01    |
| <b>2. IMPORTANT NOTE</b>                       | 01    |
| 2.1. <i>Battery Requirements</i>               | 01    |
| 2.2. <i>Battery Caution</i>                    | 01    |
| 2.3. <i>Battery Preservation</i>               | 01    |
| 2.4. <i>Memory Card Specification</i>          | 01    |
| 2.5. <i>Regarding App Wi-Fi Connection</i>     | 02    |
| 2.6. <i>Remove Protective Films</i>            | 02    |
| 2.7. <i>On-Screen Information</i>              | 02    |
| <b>3. INTRODUCTION</b>                         | 03    |
| 3.1. <i>About the Camera</i>                   | 03    |
| 3.2. <i>Main Features</i>                      | 03-04 |
| 3.3. <i>Applications</i>                       | 04    |
| <b>4. PARTS AND CONTROLS</b>                   | 05-08 |
| <b>5. INSTALLING THE BATTERIES AND SD CARD</b> | 09    |
| 5.1. <i>Loading Batteries</i>                  | 09-10 |
| 5.2. <i>Inserting the SD Card</i>              | 10-11 |
| <b>6. USING THE CAMERA</b>                     | 12    |
| <b>7. THE OFF, ON, AND SET MODES</b>           | 12    |
| 7.1. <i>OFF Mode</i>                           | 13    |
| 7.2. <i>SET Mode</i>                           | 13    |
| 7.3. <i>ON Mode</i>                            | 14    |
| <b>Shortcut Keys/Functions</b>                 | 15    |

|  |       |
|--|-------|
| <b>8. WI-FI CONNECTION</b>                     | 15    |
| 8.1. <i>Download TrailCam Go Mobile APP</i>    | 15    |
| 8.2. <i>Enable Wi-Fi and Bluetooth</i>         | 16    |
| 8.3. <i>Add Your Camera</i>                    | 16    |
| 8.4. <i>Choose Device Type</i>                 | 17    |
| 8.5. <i>Search Your Camera and Link</i>        | 17-18 |
| 8.6. <i>App Navigation</i>                     | 19-20 |
| 8.7. <i>Account Registration</i>               | 21    |
| <b>9. ADVANCED SETTINGS</b>                    | 22-27 |
| <b>10. MOUNTING AND POSITIONING THE CAMERA</b> | 27    |
| 10.1. <i>MOUNTING</i>                          | 27-28 |
| 10.2. <i>SENSING ANGLE AND DISTANCE TESTS</i>  | 29-30 |
| 10.3. <i>SWITCHING ON THE CAMERA</i>           | 30    |
| <b>11. REVIEW PHOTOS OR VIDEOS</b>             | 30-31 |
| <b>12. TECHNICAL SPECIFICATIONS</b>            | 31-33 |
| <b>13. FAQs</b>                                | 33    |
| 13.1. <i>IMPORTANT NOTE</i>                    | 33-34 |
| 13.2. <i>FAQs</i>                              | 35-48 |
| <b>14. WARRANTY</b>                            | 47    |
| <b>15. FCC COMPLIANCE STATEMENT</b>            | 49-50 |

## 1. IN THE BOX

1x Trail Camera, 1x Mounting Strap, 1x Base of Stand Set,  
1x USB Cable, 1x Instruction Manual, 1x Memory Card,  
8x 1.5V AA Alkaline Batteries

EN

*Note: A memory card has been inserted into the card slot.*

## 2. IMPORTANT NOTE

### 2.1. Battery Requirements

This camera requires a total of eight (8) 1.5V AA Alkaline or Lithium batteries for power. We highly recommend using Energizer AA Alkaline batteries to maximize battery life.

### 2.2. Battery Caution

Please do not mix old and new batteries, and avoid mixing different battery types. 1.2V Rechargeable AA batteries are NOT recommended, as they may produce lower voltage, which can lead to operational issues.

### 2.3. Battery Preservation

Remember to remove the batteries when the camera is NOT in use to prevent unnecessary power drain.

### 2.4. Memory Card Specification

This camera requires a memory card with a maximum capacity of 128GB, rated at Class 6 or above for optimal performance. We recommend using SanDisk 64GB SDHC/Class 10 memory cards for a cost-effective and reliable choice.

*Before first use, please format your memory card in the camera by using "Memory Card Format" in the menu settings.*



support@kjkcam.com

## **2.5. Regarding App Wi-Fi Connection**

For optimal performance when connecting your phone to the camera via Wi-Fi, we suggest keeping your phone within a range of 15 meters (approximately 45 feet) from the camera. Interference from various sources can affect the signal quality. If you encounter connectivity issues or a weak signal, please try moving your phone closer to the camera step by step to establish a stable connection.

Legal Attribution:

Apple and the Apple Logo are trademarks of Apple Inc., registered in the U.S. and other countries.

Google Play and the Google Play logo are trademarks of Google LLC.

These trademarks are the property of their respective owners and are not associated with our product or company.

## **2.6. Remove Protective Films**

Before using the camera, please ensure that you have removed any protective films on the front of the camera. This step is crucial to achieve the best performance.

## **2.7. On-Screen Information**

The number displayed in the top right corner of the screen indicates either the length of video that can be recorded or the number of photos that can be taken, depending on the camera's current mode.

We hope this information enhances your experience with our camera. If you have any further questions or require assistance, please don't hesitate to reach out to our customer support team.



## 3. INTRODUCTION

### 3.1. *About the Camera*

EN

The KJK228 heralds a new era in trail cameras. Overflowing with advanced features, this camera is meticulously crafted to enhance your outdoor monitoring experience.

With a built-in Wi-Fi and Bluetooth module, the KJK228 ensures effortless connectivity and camera control through our dedicated "TrailCam Go" App. The low-power Bluetooth module expedites device discovery, while Wi-Fi enables live previews, seamless image transmission, and hassle-free settings adjustments.

Our camera proudly showcases cutting-edge imaging technology, including smart night vision, blur reduction, and noise reduction, all working harmoniously to deliver pristine high-resolution image quality.

Experience the future of trail cameras with the KJK228. Uncover the beauty of the outdoors while staying effortlessly connected and in control.

### 3.2. *Main Features*

- Bluetooth for device discovery
- Wi-Fi for preview, playback, and settings
- Captures high-quality media: 84MP still photos, 8K 30fps H.264 video clips with audio
- Exceptional night vision with a 90ft flash range;
- Wide 140° view angle
- User-friendly program with intuitive operation keys and a built-in 2.0 inch color screen, simplifying programming and media review

- Two modes available: Motion detection and Time lapse
- Swift performance with a 0.05s trigger time, 0.05s recovery time, long 100ft trigger distance, and a 140° detection angle
- Each capture includes an info strip displaying Date, Time, Temperature, and Moon phase
- Additional features: Work Time tracking, Loop Recording, Time Lapse, Password Protection
- Designed for all climates with IP67 rating; operational in temperatures ranging from -22°F to 158°F
- Supports SD/SDHC/SDXC memory cards, with a maximum capacity of 128GB

EN

### 3.3. Applications

**The camera is versatile and can be utilized in various ways:**

- **Hunting:** Capture animals' tracks and behaviors in their natural habitat.
- **Wildlife Observation and Research:** Record pictures and videos of wild animals in their natural environment.
- **Sports Camera:** Perfect for activities like riding, driving, camping, or exploring, allowing you to capture your adventures.
- **Motion-Triggered Security Camera:** Ideal for home, farm, office, and community surveillance, ensuring security and peace of mind.
- **Indoor and Outdoor Surveillance:** Suitable for both indoor and outdoor applications where evidence of intrusion or monitoring is needed.



## 4. PARTS AND CONTROLS

The camera is equipped with built-in multiple high efficiency infrared LEDs, LED Indicators, Lens, 3pcs PIR Sensors, Lock Holes in front view (**Figure 1**).

EN

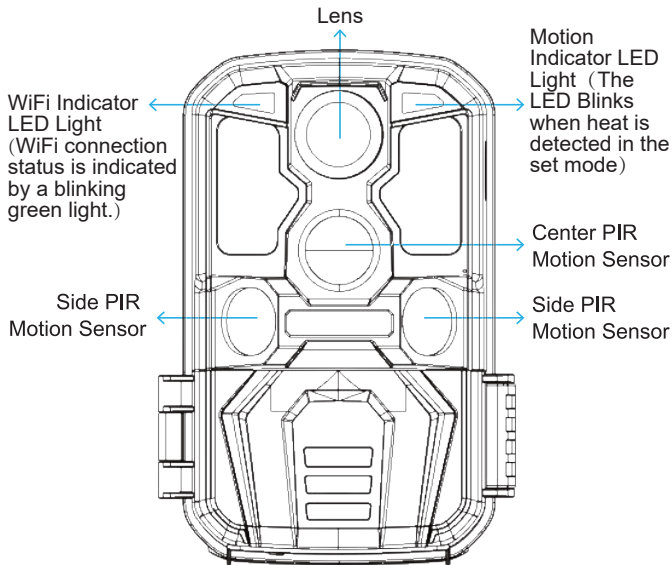
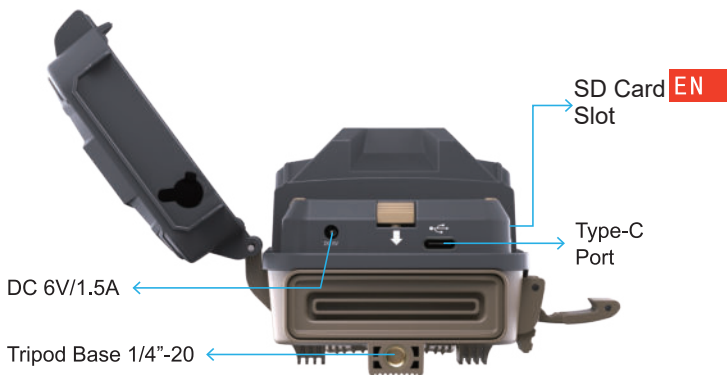

Figure 1: Front View

The camera provides the following connections for external devices: USB port and SD card slot etc. (**Figure 2**).





*Figure 2: Bottom View*

The camera has 2 strap holes on the back. The strap can be put through the strap holes and fastened securely around the tree trunk by pulling the end of the strap firmly (**Figure 3**).

EN



*Figure 3: Back View*

The camera has a 2.0-inch built-in LCD screen, which can be used for reviewing pictures or videos and menu displaying, and unique keypad design for easy program and operation, 8 AA batteries slot.



Figure 4: Inside View



Figure 5: Operation Keys and Shortcut

## 5. INSTALLING THE BATTERIES AND SD CARD

Before you begin learning how to use your camera, you will first need to install a set of batteries and insert an SD card.

EN

Although that may only take you a minute, there are some important notes about both batteries and SD cards you should be aware of, so please take the time to **read the following directions and cautions:**

### 5.1. Loading Batteries

After opening the battery compartment cover, you'll notice that the camera features eight battery slots (**Figure 6**). To ensure the camera operates correctly, it's essential to insert all eight batteries with the correct polarity, ensuring the negative or "flat" end aligns with the long spring in each battery slot.

Regarding rechargeable the battery, for optimal performance, use 1.5V rechargeable lithium-ion batteries. They store more power than regular alkalines and perform better, especially in cold outdoor conditions. Avoid low-quality NiCd or Nickel Metal Hydride rechargeables, as they store less power and underperform compared to standard alkalines.

During **SET** mode, when the battery power level becomes low, you will see the message "**Low Battery**" displayed on the screen. At this point, it's important to replace the batteries.

Please keep in mind that when the battery charge drops to **1/3**, the Night Vision function will automatically deactivate. You can monitor the remaining power in the bottom right corner of the screen. It's worth noting that the camera consumes more power during nighttime operation due to its built-in IR LEDs. To



[support@kjkcam.com](mailto:support@kjkcam.com)

maximize battery life during night use, we recommend using 1.5V AA alkaline batteries, particularly 8 Energizer brand batteries, as they offer a battery life two to three times longer than regular batteries.

EN



*Figure 6: Loading the Batteries*

## 5.2. Inserting the SD Card

Insert the SD card (with the camera's power switch in the OFF position) before beginning to operate the camera. Don't insert or remove the SD card when the power switch is in the **ON** or **SET** mode. The camera uses a regular memory card to save photos (in .jpg format) and/or videos (in .mp4I format). SD cards up to a maximum 128GB capacity is supported (**Figure 7**).

**The following describes how to insert and remove the SD card:**

- Insert the SD card into the card slot with its label side upwards. A "click" sound indicates that the card is installed successfully. If the wrong side of the card is facing up, you will not be able to insert it without force, there is only one correct



way to insert cards. If the SD card is not installed correctly, the device will not display an SD card icon on the screen in SET mode. Formatting Memory card by using the camera's "Format" parameter in the menu settings before using it for the first time is recommended, especially when a card has been used in other devices.

- To take out the SD card, just gently push in the card (do not try to pull it out without pushing in first). The card is released from the slot and ready to be removed when you hear the click. Be sure the camera's power is switched OFF before inserting or removing SD cards or batteries.



*Figure 7: Inserting the SD Card*

## 6. USING THE CAMERA

Once you've prepared your camera with the correct installation of batteries and an SD card, you can simply take it outdoors and secure it to a tree (or based on your specific application scenario). Switch it **ON** and leave it to capture potential great photos that match your expectations. However, we strongly recommend that you initially invest some time indoors with this manual (Alternatively, you can visit our website at "[www.kjkcam.com](http://www.kjkcam.com)", where we regularly update instructional videos and FAQs to assist you in using our products) along with your camera. This will help you familiarize yourself with the functions of those control keys.

At the very least, you may want to set the date and time so that the camera can imprint them (or not, as it's your choice) on your photos as they are taken. You can also learn how to configure the camera to shoot video clips instead of still photos if that's your preference. Additionally, reading some tips on how to mount it securely on a tree can be beneficial.

## 7. THE OFF, ON, AND SET MODES

The camera has three basic operational modes:

- **OFF** mode: Power switch in the **OFF** position.
- **SET** mode: Power switch in the **SET** position (screen is on).
- **ON** mode: Power switch in the **ON** position.

App & WiFi Connection:

You can use the APP(TrailCam Go) to connect the camera when the camera is operating in the ON or SET modes.



### 7.1. OFF Mode

EN

The **OFF** mode is the "safe" mode when any actions must be taken, e.g., replacing the SD card or batteries, or transporting the device. And of course, when you are storing or not using the camera, you will switch it to OFF. Please note that in the OFF mode the camera consumes little power. It's a good idea to take the batteries out of the battery compartment if the camera will not be used for a long time.

### 7.2. SET Mode

In **SET** mode, you can easily review and adjust your camera's settings using the built-in screen. To access these settings, simply press the **MODE** key twice to bring up the menu. Within this menu, you have the ability to modify various parameters such as photo or video resolution, the time interval between photos, enabling or disabling time imprinting, and more (for further details, refer to **Section 9 ADVANCED SETTINGS**).

When you shift the power switch to the **SET** position, the screen will activate, displaying essential information like the available image capacity, battery level, camera or video mode, and more.

Please take note: In **SET** mode, if there is no activity (key pressing) within 2 minutes, the camera will automatically turn off the screen to conserve power.

In **SET** mode, you can also connect the camera to a computer's USB port to download your images.



### 7.3. ON Mode

Anytime after the batteries and SD card have been inserted, you can switch on the camera. When the power switch is moved to the topmost position, the camera will enter into the ON mode. The camera will countdown 15second delay and then be ready to capture images. Once in the **ON** mode, no manual controls are needed or possible (the control keys have no effect). The camera will take photos or videos automatically (according to its current parameter settings).

EN

You can either move the power switch directly from **OFF** to **ON** mode, or stop at the **SET** position first to change one or more settings, then move the switch to **ON** after you have finished doing so.

#### Shortcut Keys/Functions

As mentioned earlier in the "Parts & Controls" section, the keypad keys serve secondary "shortcut" functions when the camera is in **SET** mode:

Press the **OK** key to quickly switch the camera to video mode. Press the **UP/Down** key to swiftly set the camera to capture still photos.

Press the **OK** key to manually trigger the shutter. This feature is handy for testing the camera.

When set to the **SET** position (the middle position), press the **MODE** key to review your photos and videos. Keep in mind that the camera should not be in the **OFF** or **ON** position for this function to work. Utilize the **DOWN** or **UP** key to navigate through your media, and finally, press the **MODE** key to exit playback mode.



## 8. Wi-Fi CONNECTION

### 8.1. Download *TrailCam Go* Mobile APP

Before using the Wi-Fi functionality, please download the “*TrailCam Go*” App.

EN



You can download the app from the app store by scanning the following QR code.



#### **NOTES:**

The screenshots provided in this section are for reference purposes only. The actual interface and layout may vary on different versions of the App, whether on iOS or Android.

While using the TrailCam Go App (referred to as the App), it's important to grant the App access to certain permissions on your device. These permissions include Wi-Fi, Bluetooth, storage, location, and camera access. Enabling these permissions is essential to facilitate the functionality of taking pictures and recording videos with the App.

For iOS users on iOS 14 and later, it's also necessary to enable the Local Network permission to ensure seamless App operation. This will help maintain connectivity and ensure the App functions as intended.

## 8.2. Enable Wi-Fi and Bluetooth

Enabling both Wi-Fi and Bluetooth on your mobile phone before launching the App is a mandatory step. This action is crucial for optimizing the connection speed between the App and the camera. EN

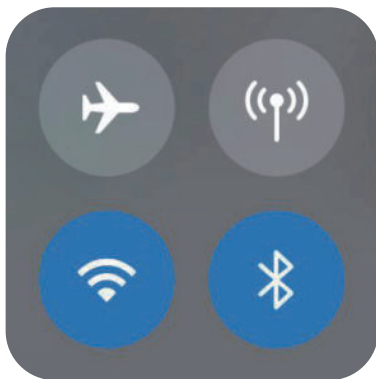

Figure 8: Enable Wi-Fi and Bluetooth

## 8.3. Add Your Camera

Make sure your camera is in ON Mode, and that it is near you. To get a stable connection, please get close to your camera no farther than **45ft** away with no obstacles between you and the camera, such as walls, glass doors etc.

To add your camera, simply tap the "+" icon in the center of the screen (**Figure 9**).



## 8.4. Choose Device Type

Please tap Wi-Fi Camera

EN



Figure 9:  
Tap to add device

Figure 10:  
Select Wi-Fi  
Camera Type

Figure 11:  
Click Next

## 8.5. Search Your Camera and Link

By default, in the list the camera will be indicated as ID "KJK\_XXXX". The App automatically searches for all Wi-Fi trail cameras nearby, please make sure your camera is within the Wi-Fi range. This process may take up to 15 seconds. If there is no device shown in the list, To return to the previous menu, click the "X" key. To refresh the list, click "Next" again (**Figure 11**) . Tap the one you want to add (**Figure 12**). The App starts connecting to your camera. It might take up to 15 seconds to build the Bluetooth and Wi-Fi connection between the App and camera. There are 4 steps (Illustration omitted):

- Step1 - Connecting through Bluetooth...
- Step2 - Searching Wi-Fi ...
- Step3 - Activating the camera...
- Step4 - Connecting through Wi-Fi...

EN



Figure 12:  
Connect Camera



Figure 13:  
Allow Wi-F- Connection on iOS Device

A system pop-up message will show (**Figure 13**).

Please tap "Join" to allow Wi-Fi connection. The string "KJK\_XXXX" is the name of Wi-Fi hotspot on the camera to allow Wi-Fi connection. Among cameras, the prefix TrailCam is fixed, XXXX is the internal camera identifier which may vary from different cameras.

NOTE: On Android devices, there might be different system pop-up messages that ask for allowing App connection to camera since different mobile phone manufacturers may modify and customize this system message.

After connected, a pop-up message would show as below:



## 8.6. App Navigation

| Features | Details  | Refer to  |
|----------|--|-----------|
| Camera   | Preview, Manual taking pictures or videos.   | Figure 14 |
| Status   | Camera status, including battery level, SD Card capacity and used size, internal temperature of the camera, number of pictures and videos stored on the SD Card, camera model, firmware version number, etc. | Figure 15 |
| Setting  | Display or program camera settings, such as mode, picture quality etc.   | Figure 16 |
| Gallery  | Review or download the pictures or videos the camera has taken.  | Figure 17 |

EN

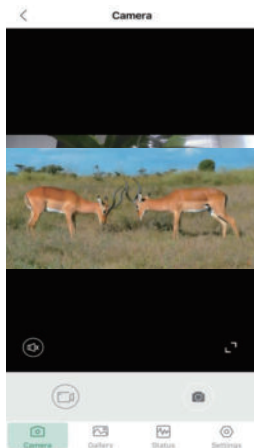

Figure 14: Camera

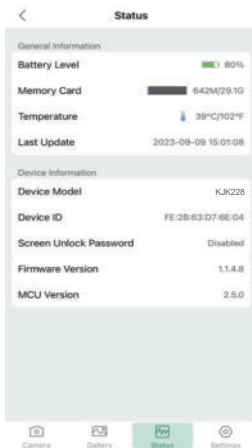

Figure 15: Status

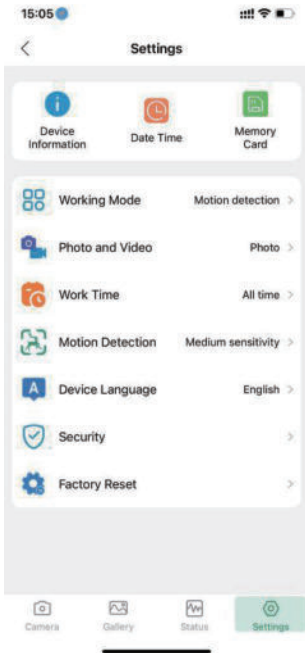

Figure 16: Settings Figure



EN

Figure 17: Gallery

## 8.7. Account Registration

To enhance the security of machine-captured and recorded content, we recommend registering your account after binding the app to your device.

EN

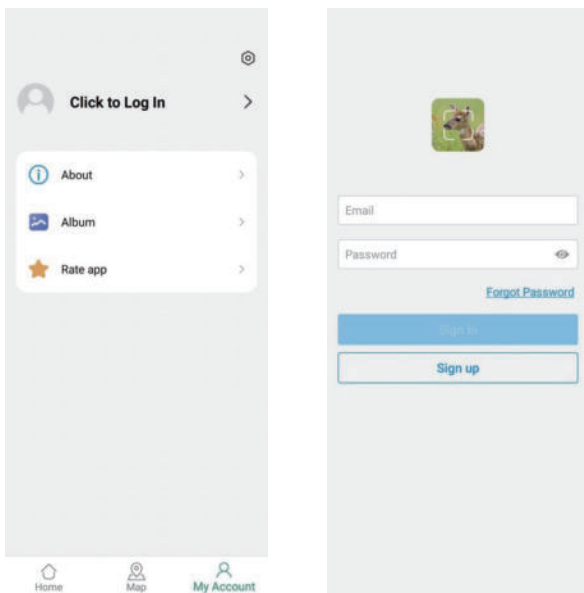

Figure 18: Account Registration



## 9. ADVANCED SETTINGS

The trail camera comes with preset manufacturer settings. You can change the settings to meet your requirements. Please make sure that the camera is in the SET mode. Once the camera screen is on, press MODE key to enter/exit the menu. Press the UP/DOWN key to change the setting, and press the OK key to confirm the change. Always remember to press the OK to save the change. Otherwise you will lose your new setting.

EN

| Parameter        | Settings<br>(Bold=default)  | Description  |
|------------------|---|--|
| Mode             | <b>Motion Detection</b><br>Timelapse<br>Normal<br>Timelapse<br>Video  | Select different mode to monitor   |
| Photo or Video   | <b>Photo</b><br>Video<br>Photo+Video                                  | Select whether still photo , video, photo&video clips are taken.   |
| Photo Resolution | <b>Smart Best Photo</b><br>84MP<br>64MP<br>48MP<br>40MP<br>...<br>4MP | Select desired resolution for still photos from 4 to 84 megapixels. Higher resolution produces better quality photos, but creates larger files that take more of the SD card capacity. Larger files require longer time to write to the SD card, which will slightly slow the shutter speed. |



|                          |   |  |
|--------------------------|---|--|
| Photo Series             | <b>1P, 2P, 3P, 4P, 5P</b>   | Select the number of photos taken in sequence per trigger in Camera mode.  |
| Video Resolution         | <b>Smart Best Photo</b><br>8K Lite<br>6K Lite<br>4K Lite<br>...<br>720P | Select video resolution (pixels per frame). Higher resolution produces better quality videos, but creates larger files that take more of the SD card capacity.   |
| Video Length             | <b>5seconds,</b><br>Optional from 5s to 3m                              | Videos are in MP4 format that can be played back on most video players (VLC/IrfanView etc.).<br>Note: Night videos are limited to a maximum of 30 seconds to conserve the batteries. If set video length higher than 30 seconds, e.g. 60 seconds, the max recording length at night keeps 30 seconds.  |
| Audio Recording          | <b>On</b><br>Off  | Selecting On will record video with sound.   |
| Shot Lag/PIR Sensitivity | <b>10 seconds,</b><br>optional from 5s to 60m                           | Select the shortest length of time that the camera will wait until it responds to any subsequent triggers from the PIR sensor after a game is first detected.<br>During the selected interval, the camera will not take pictures/videos.<br>This prevents the micro SD card from filling up with too many redundant images.<br>Note: This option is invalid if Mode is set as "Time Lapse" |

|                 |   |  |
|-----------------|---|--|
| PIR Sensitivity | High<br><b>Middle</b><br>Low                      | <p>The "High" level will make the camera more sensitive to infrared (heat) and more easily triggered by motion, the "Low" level makes it less sensitive to heat and motion. The "Middle" is for average or moderate conditions. Commonly, the "High" level is suitable when the ambient temperature is warm and little interference (interference such as windy), and the "Low" level is helpful in cold weather. Note: This option is invalid if Mode is set as "Time Lapse"</p>                                |
| Work Time       | On<br><b>Off</b>                                  | <p>Select On if you only want the camera to work within a specified time period every day. For instance, if the starting time is set at 18:35 and the ending time at 08:25, the camera will function from 18:35 the current day to 08:25 the next day. Outside the time period the camera will not be triggered or take photos/videos.</p>   |
| Timelapse       | On<br><b>Off</b><br>optional<br>from 1s to<br>24h | <p>When the "Time Lapse" feature is enabled, the camera will automatically take photos/videos according to the set interval (1 Min ~ 24 Hours can be set) regardless of whether the motion sensor has detected any game. For example, after setting the interval time to 1H, and the camera will take a photo or record a video every hour (confirm whether to take a photo or record video based on your work mode), the camera will take 24 photos within 24H. This is helpful when observing cold-blooded</p> |



|           |                |   |
|-----------|----------------|---|
|           |                | <p>animals like snakes, or the process of flowering etc.</p> <p>Note: Too small interval set in the Time Lapse Settings will enable to take more pictures, but can consume more battery power then reduce battery life accordingly.</p> <p>Note: this mode will disable motion detection.</p>   |
| Date/Time | M/D/Y<br>hh:mm | <p>M-Month<br/>D-Day<br/>Y-Year<br/>hh-Hour<br/>mm-Minute</p> <p>Press the Mode key to access the menu options. Use the navigation keys to select the "Time &amp; Date" option and press the OK key to enter the settings. Adjust the time and date according to the local time. To modify a specific value, use the UP/DOWN keys to navigate to the desired field and press the OK key to select it. Use the UP/DOWN keys to modify the value of the selected field. For example, for the hour or month, you can increase or decrease the value. After making the necessary modifications, press the OK key to confirm and save the changes. To set the time format, follow these additional steps: In the "Time &amp; Date" settings, find the option for time format (12 or 24-hour format). Use the OK key to select the desired time format. If the 12-hour format is selected, the captured</p> |



|                     |                        |   |
|---------------------|------------------------|---|
|                     |                        | images and videos will display AM and PM water marks. For example, in the 24-hour format, the time and date would be displayed as "March 8,2023,15:46:29" while in the 12-hour format, it would be displayed as "March 8,2023,3:46:29 PM".  |
| Date Format         | D/MY<br>M/D/Y<br>Y/M/D | Select date format which will be shown on the screen and each capture.  |
| Time Format         | <b>12h</b><br>24h      | Select time format which will be shown on the screen and each capture. 12h-AM/PM.   |
| Motion Test         |                        | This feature helps you aim the camera at your target area. Please refer to the details in <i>Section 10.2</i> .   |
| Password Protection | On<br><b>Off</b>       | Set a 4-digit password to protect your camera from unauthorized users. If the code is lost, turn the power switch to "OFF" at first. Then press "OK" key and "UP" key at the same time (Don't let go of your fingers) and turn the power switch to "SET" Password will be cleared automatically when the camera starts. |
| Beep Sound          | On<br><b>Off</b>       | Choose to turn on or off.   |
| Memory Card Format  | Yes<br>No              | All files will be deleted after formatting the SD card. Highly recommend you format the SD card if it has been used previously in other devices. Caution: make sure wanted files on the SD card have been backed up first!  |



|               |           |   |
|---------------|-----------|---|
| Camera Name   | On<br>Off | Select On to assign a 4-character long in the form of Capital A-Z, 0-9 to record the location in the photos (e.g. A123 for Yellow Stone Park). This helps multi-camera users identify the location when reviewing the photos. |
| Factory Reset | Yes<br>No | Selecting Yes will return all your previous settings back to the manufacturer default.  |
| Version Info  | Defined   | Display the version of the camera   |

## 10. MOUNTING AND POSITIONING THE CAMERA

### 10.1. MOUNTING

After you've set up the camera's parameters to your personal preferences at home, you're ready to take it outside and slide the power switch to "ON". When setting up the camera for scouting game or other outdoor applications, you must be sure to mount it in place correctly and securely. We recommend mounting the camera on a sturdy tree with a diameter of about 6 in (15cm). To get the optimal picture quality, the tree should be about 16- 17 ft. (5 meters) away from the place to be monitored, with the camera placed at a height of 2.5-3.5 ft. (0.75-1m). Also, keep in mind that you will get the best results at night when the subject is within the ideal flash range, no farther than 65ft (20m) and no closer than 10ft (3m) from the camera.

**Note:** Aiming a camera North will prevent capturing overexposed photos pointed directly at the sun.

There are two ways to mount the camera: using the provided adjustable web belt, or the tripod socket.

Using the adjustable strap: Illustrates using the strap on the camera. Push one end of the strap through the two brackets on the back of the camera. Thread the end of the strap through the buckle. Fasten the strap securely around the tree trunk by pulling the end of the strap firmly so there is no slack left (**Figure 18**).

Using the tripod socket : The camera is equipped with a socket at the bottom end to enable to mount on a tripod or other mounting accessories with a standard UNC 1/4-20 thread screw.



Figure 18: Strap



## **10.2. SENSING ANGLE AND DISTANCE TEST**

To test whether the camera can effectively monitor the area you choose, this test is recommended checking the sensing angle and monitoring distance of the camera. To perform the test:

EN

Switch the camera to the SET mode.

The camera will countdown a max 10-second delay and be ready to capture motions. (Note: The delay time may be less than 10 seconds, depending on the actual time of the motion sensor to be activated. The delay time is 10 seconds minus the power-on time.) Close the camera door.

Make movements in front of the camera at several positions within the area where you expect the game or subjects to be. Try different distances and angles from the camera.

If the motion indicator LED light (Blue for Center PIR or Green for Side PIR) blinks, it signifies that the position is detectable. If it does not blink, that position is outside of the sensing area. In these sensing test, the camera would take pictures once motion captured. When you open the camera, the screen shows the number of times triggered, you can review the pictures on the screen.

The results of your testing will help you find the best placement when mounting and aiming the camera. The height away from the ground for placing the device should vary with the animal size appropriately. In general, 3 to 6 feet is preferred.

You can avoid potential false triggers due to temperature and motion disturbances in front of the camera by not aiming it at a heat source or nearby tree branches or brush (especially on



windy days).

Do NOT install the camera behind the glass window as that is not possible to sense any motion. Avoid the camera toward to glass the object.

EN

### **10.3. SWITCHING ON THE CAMERA**

If you set the camera working mode as "Time Lapse" in the menu, once you switch to the ON mode, the camera will be ready to go into "Time Lapse" mode, then take images periodically according to your preset "Time lapse Interval" parameter. Before leaving the camera unattended, please check for the following:

Are the batteries inserted with correct polarity and is their power level sufficient?

Does the SD card have sufficient available space?

Is the power switch in the ON position?

## **11. REVIEW PHOTOS OR VIDEOS**

After you have setup, mounted and activated your CAMERA, you will be eager to return later and review the images it has captured for you. The camera stores photos and videos in the folder \DCIM in the SD card. Photos are saved with file names like DSCF0001.JPG and videos like DSCF0001.MP4. The MP4 video files can be played back on most popular media players, such as Windows Media Player, VLC etc.

There are several different ways this can be done.

To view photos or videos directly on the camera screen, simply tap the MODE button.



Or in the SET mode only, you can use the provided USB cable to download the files to a computer.

Or you can put the SD card to a SD card "reader" (user supplied), plug in a computer, and browse the files on the computer without downloading.

EN

## 12. TECHNICAL SPECIFICATIONS

| Element         | Description   |
|-----------------|---|
| Max. Pixel Size | 84MP  |
| Lens            | FOV=90°   |
| IR Flash        | 100ft   |
| LCD Screen      | 2.0 " Color Screen  |
| Keypad          | 4 Keys, 1 Power Switch                                    |
| Memory          | SD, SDHC or SDXC Memory Card,<br>Max Capacity 128GB       |
| Picture Size    | 4M/8M/16M/24M/32M/40M/48M/64MP/<br>84MP/ Smart Best Photo |
| Video Size      | 720P/1080P/2.7K/4K/6K/8K/Smart<br>Best Photo              |
| PIR Sensitive   | High/Middle/Low   |

|                            |   |
|----------------------------|---|
| PIR Sensing Distance       | 100ft(-22° F to +158°F.)  |
| PIR Sensing Angle          | Total 140°  |
| Work Time                  | Approx. 0.05~0.5 second<br>(0.05s while side motion sensors enabled)                              |
| Shot Lag/<br>Dection Delay | 5sec-60min, Programmable.   |
| Photo Series               | 1~5   |
| Video Length               | 5sec ~ 10min., Programmable<br>(Note: Max 30 seconds at nighttime to conserve batteries lifetime) |
| Work Time                  | On /Off, Specific working period of time  |
| Password Protection        | 4-Digit Code  |
| Camera Name                | 4-Character (A-Z, 0-9)  |
| Time Lapse                 | 1 Sec. ~ 24 Hours   |
| Power Supply               | 8x1.5V AA Alkaline Batteries  |
| Auto Stand-by              | Auto Stand-by (Surveillance mode) in 2 minutes while no operation in SET mode                     |
| Interface                  | Type C-USB, SD card holder, External Power (DC 6V/ 1.5A, Plug 3.5x1.35mm)                         |

EN



|                       |  |
|-----------------------|--|
| Mounting              | Strap, Tripod Base ( 1/4"-20)            |
| Waterproof            | IP67                                     |
| Operation Temperature | -22° F to +158°F.                        |
| Operation Humidity    | 5% ~ 95%                                 |
| Certificate           | FCC & CE & RoHS & WEEE                   |
| Product Dimensions    | 5.43 x 15.08 x 4 inches/138 x 383 x 62mm |
| After-sales           | support@kjkcam.com                       |

## 13. FAQs

### 13.1. IMPORTANT NOTE

- Before inserting or removing the memory card, make sure the camera is turned off.
- When checking the camera in SET mode, the ambient light source may be unstable due to handheld movement. This can trigger the motion sensor, resulting in a clicking sound and a flashing screen. This is normal.
- It is recommended to use high-performance alkaline batteries to extend the camera's usage time.
- Avoid using 1.2V rechargeable batteries as the trail camera



requires 1.5V for proper functioning. Low battery voltage can lead to improper operation. After the battery is depleted, the camera will only have a few hours of operation remaining (the camera will display a low battery warning).

EN

- When using the trail camera for the first time or if the camera cannot recognize the memory card, please format the memory card before use. Before installing the battery, confirm the correct battery polarity. Incorrect polarity may cause the camera to short-circuit and potentially damage it. Please note that the camera is not protected against short circuits.
- When using the product for the first time, remove the protective film from the lens and sensor to ensure the motion sensor is clean and undamaged. Any scratches or damage can affect the camera's triggering performance.
- For on-site installation, ensure that the camera's socket and the DC plug at the bottom are properly sealed to prevent damage from rain.
- The USB cable provided is for transferring files from the camera to the computer only. Do not use it to charge the camera or rechargeable batteries as this can severely damage the camera.
- Keep the camera lens and infrared window clean. If they become dirty, clean them with a soft glasses cloth. Do not use sharp objects that may scratch the LCD, camera lens, infrared sensor, or LED glass.
- When the battery level is low, promptly replace all batteries to avoid damage to the camera due to electrolyte leakage.

# FAQ Catalog

|  |    |
|--|----|
| <b>PART1: WiFi Connection and App</b> .....  | 35 |
| Q: App will not connect to camera via Wi-Fi/Blue-tooth.....  | 35 |
| Q: Do I have to be close to use the app? Or can I be in a different state and see while I am not at home?..... | 36 |
| Q: Can't connect to home Wi-Fi router.....   | 36 |
| Q: My Wi-Fi trail camera is not found by the TrailCam GO App.....  | 36 |
| Q: Wi-Fi connected, but can't see any camera information and can't preview .....                               | 36 |
| <br><b>PART2: About Recording Issues</b> .....   | 36 |
| Q: Can't recording video.....  | 36 |
| Q: It looks overexposed or the background of the night picture is too dark .....                               | 38 |
| <br><b>PART3: About Batteries, Power Supply</b> .....  | 39 |
| Q: Battery life is shorter than expected .....   | 39 |
| Q: Can it use rechargeable NiMH batteries or Lithium batteries? .....  | 39 |
| Q: Does the camera have a port for an external power? .....  | 40 |
| Q: Can an external power source and internal 8 batteries work together? .....                                  | 40 |

|  |    |
|--|----|
| <b>PART4: About Motion Detection Issues</b> .....  | 41 |
| Q: Camera stops taking images or won't take images.....  | 41 |
| Q: Camera does work, but can't capture motions .....   | 42 |
| Q: Camera takes continuous images of no subject .....  | 42 |
| Q: Photos do not capture subject of interest.....  | 43 |
| <br>   |    |
| <b>PART5: About Video Sound</b> .....  | 44 |
| Q: The video is very clear, but the sound is not good .....  | 44 |
| <br>   |    |
| <b>PART6: About SD Card</b> .....  | 44 |
| Q: There are problems with SD card access, such as not<br>being recognized, the inability to delete photos, read/open<br>photos or videos, etc. .... | 44 |
| <br>   |    |
| <b>PART7: About Camera Screen</b> .....  | 45 |
| Q: When I turn on the camera, the screen just continually<br>flashes white .....   | 45 |
| <br>   |    |
| <b>PART8: About Turn On</b> .....  | 45 |
| Q: Camera won't power up .....   | 45 |
| <br>   |    |
| <b>PART9: Other Issues</b> .....   | 46 |
| Q: What if I forget my camera password?.....   | 46 |
| Q: Why is there air in the trail camera? Is it a leak?.....  | 46 |
| Q: Can this Wi-Fi trail camera connect to more than one<br>phone?.....   | 46 |

## **PART1: WiFi Connection and App**

### **Q: App will not connect to camera via Wi-Fi/Bluetooth**

**The following reasons may cause WiFi to not connect properly:**

EN

The camera and cell phone are too far apart: Please ensure that the distance between the camera and cell phone does not exceed 45ft (in an open environment without any obstructions). If exceeding this distance, the cell phone will not be able to recognize the signal of the camera.

VPN and antivirus software in cell phones: Some VPN and antivirus software may restrict the WiFi connection between the camera and app.

Cell phone cache: When there is too much cache in the cell phone, it will cause WiFi connection to be slow, clean up the cache regularly.

### **Please try the following trouble shootings:**

After receiving the camera, please download the latest version of the app on your phone and make sure that WiFi and Bluetooth on your phone are turned on.

Open the app, during the connection process, please allow the app to access the device's WiFi, Bluetooth, storage, location, and camera. For the first connection, we recommend that the distance between the phone and the camera is within 45ft.

Check APN and antivirus software: Please make sure they are turned off or allowed cell phone to use WiFi.

**Q: Do I have to be close to use the app? Or can I be in a different state and see**



### **while I am not at home?**

The Wi-Fi trail camera can only work with the app within Wi-Fi and Bluetooth signal range.

You have to be within Bluetooth range to connect and then it puts out its own Wi-Fi signal to your phone to view pictures.

EN

### **Q: Can't connect to home Wi-Fi router**

The Wi-Fi trail camera can only be connected with your phone by the dedicated app ("TrailCam GO").

### **Q: My Wi-Fi trail camera is not found by the TrailCam GO App**

Please make some quick check:

1. Get as close to the camera as possible (within 45ft due to the limitation of Bluetooth technology).
2. The camera is turned on.
3. Wi-Fi option in the camera is enabled.
4. Make sure the camera battery level is good.
5. Both Bluetooth and Wi-Fi on your phone are enabled.

### **Q: Wi-Fi connected, but can't see any camera information and can't preview**

On iOS 14.4.1 or above, please use the Settings app, go to the Privacy menu, then select Local Network. It will show a list of all the apps that have requested permission giving the app access to devices on the network.

## **PART2: About Recording Issues**

### **Q: Can't recording video**

The following reasons may cause camera not recording



**properly:**

Low battery: The camera needs to turn on the IR LEDs when working at night, which consumes more power than working during the day. If the voltage is low, it will record shorter videos or not record videos.

**EN**

The camera is not programmed to Video mode.

Wrong SD card file system: The incompatibility of SD card formatting with the camera may cause the videos/pictures shot by the camera to be unable to be stored in the SD card, thereby making customers think that the camera has not taken correctly.

Wrong settings of "Work Time": If the Work Time is set, the camera will only work during this time, and it will be in standby at other times.

**Please try the following trouble shootings:**

After receiving the camera, please install a set of brand new alkaline .

Ensure the camera is set to Video mode: The camera defaults to Photo mode when it comes out of the factory. If you want to record a video, you need to manually adjust the shooting mode (MODE >Photo or Video > Video)

Format the SD card before first using the camera by the way: press MODE, go to 'Format memory card' to ensure the SD card working in right file system.

Check if the camera has been set "Work Time" as your expected.

Also you can run a motion test:

After configuring the device, switch it to "SET" mode.

Wait for approximately 15 seconds.



[support@kjkcam.com](mailto:support@kjkcam.com)

Move to the front of the camera.

If the motion indicator flashes "blue" or "green", it confirms the proper functionality of the camera's infrared motion sensor ".

**Q: It looks overexposed or the background of the night picture is too dark**

EN

The dark background of night images is usually caused by strong reflections from the obstacles close to the camera. To get the best night image, please remove close-up obstacles (such as walls or tree trunks) in front of the camera as possible, or adjust the installation position of your camera to avoid these obstacles (*Refer to the figure below*).



### **PART3: About Batteries, Power Supply**

#### **Q: Battery life is shorter than expected**

**The following reasons may cause battery lifetime not as expected:**

EN

Battery quality and cold temperature will affect the battery lifetime.

Too many unwanted false triggers causing the battery to drain quickly. Branches or weeds that can be blown by the wind, and trigger the capture.

Excessive settings cause the camera to capture too many redundant and repetitive pictures, leading to fast battery consumption.

#### **Please try the following trouble shootings:**

Please use brand new batteries to power the camera, and use 1.5V lithium batteries when the weather is cold to get better battery lifetime.

Set the camera working mode reasonably according to the usage scenario. Check the camera settings such as Photo Series, Sensitivity Motion, Shot Lag, etc. To reduce unnecessary triggers. For common usage, we recommend "Photo series" is 1, "Sensitivity motion sensors" is Middel, "shot lag" is 10s.

Avoid false triggers: avoid objects such as branches or weeds that can be blown by the wind when placing the camera.

If the frequency of using the camera is very high, we recommend using an external power supply to power the camera.

#### **Q: Can it use rechargeable NiMH batteries or Lithium batteries?**

 [support@kjkcam.com](mailto:support@kjkcam.com)

Yes. Lithium batteries are better used in cold weather. We recommend using new eight 1.5-volt rechargeable lithium-ion batteries to get maximum batteries lifetime. They're generally marketed and sold in sets of four AA batteries plus a convenient 4-cell charger, all for usually about \$25.00 - \$30.00. NiMH rechargeable batteries cannot also be used.

EN

Note: While all AA batteries will take decent daytime images and daytime videos, the nighttime camera performance will suffer, or not work at all when using AA batteries that have a voltage less than 1.5 volts.

Don't use the batteries' voltage greater than 1.5V which would damage the camera. Don't mix old and new batteries. Don't mix battery types.

**Q: Does the camera have a port for an external power?**

Yes. The port is on the bottom of the camera. The camera can work with 6V/1-15A external power adapter/source (user supplied). The cable end of DC must be the circles of 3.5mm outside, 1.35mm inside (that is 3.5×1.35mm) and the central contact point is positive polarity.

It is easy to find the cable or adapter on Amazon (searching the items by "DC 6V 1A 3.5×1.35mm"), or electronic marketplace.

**Q: Can an external power source and internal 8 batteries work together?**

Yes. It can. The camera can accept external power (user supplied) and work with internal batteries at the same time. The camera will automatically use the higher voltage of the two as the input power source.



When the external power supply is removed, the camera will automatically switch to use the internal battery. Please do not use an external power supply exceeding 6V.

EN

## **PART4: About Motion Detection Issues**

### **Q: Camera stops taking images or won't take images**

1. Please gently remove the protective films of the camera to get the best performance, especially the protective films attached to the PIR sensors will seriously reduce the motion detection ability and even cause no capture.
2. Make sure that the camera power switch is in the "ON" position and not in the "OFF".
3. Make sure the camera had been powered up for more than 60 seconds to ensure the PIR sensors have been fully activated.
4. Check the "shot lag" in menu settings, which is the delay between current capture and next capture, set "shot lag" to a lower value if you want more captures.
5. Please make sure that the SD card doesn't reach its full capacity. The default option is "Loop Recording" disabled; the camera will stop taking images when the SD card reaches capacity.
6. Make sure that you are using a good quality SD card in your camera. We recommend SD/SDHC/SHXC Class10 brand memory card, such as SanDisk, Kingston, Toshiba, Samsung, etc.
7. IMPORTANT: If you have used an SD card in another device before inserting it in your camera, you might want to try format-



[support@kjkcam.com](mailto:support@kjkcam.com)

ting the card using the "Memory Card Format" menu option in SET mode (make sure you have backed up any important files first, as formatting will erase all previous files). In some cases, other devices may change the formatting of the SD card so that it will not work properly with the camera. Or if the SD card has been used for a long time, the SD card might be in unstable status and not able to accept data writing into, in this case, the camera behaves as not triggering and not taking pictures. So please re-format SD card and try again.

EN

8. **IMPORTANT:** Check the batteries to make sure their power level is sufficient. If you are using rechargeable batteries, it would not take nighttime pictures or videos due to the low battery voltage (generally nominal 1.2V and drops down quickly). Please use 1.5V batteries instead.

9. Run motion detection test by "Motion Test" menu option to check whether the motion sensor does work.

### **Q: Camera does work, but can't capture motions**

The problem is generally caused by incorrect file system format on your SD card. Please format your SD card according the following steps:

Press MODE key, go to "Memory Card Format", select "OK".

### **Q: Camera takes continuous images of no subject**

A camera has what is known as a "false trigger" if the PIR sensor thinks that there is motion and heat in front of the camera lens when there is no subject in the image. These "False Triggers" are the result of placing the camera in an environment where there is motion associated with tree



branches creating motion in front of the camera or an area where there is high heat in the foreground and any motion from wind could set off the camera. Setting a camera up over water is also a potential cause for this issue. To remedy this situation:

1. Try moving the camera to an area that does not have any of these issues or try changing the sensor level on the menu settings.
2. If the camera continues to take images when there is no subject in them, try placing the camera in an inside environment and aiming at a location where there is no motion.
3. If the camera continues to show issues, then there is probably an electronic component issue. If this is the case, please contact our customer service to send the camera back for repair or a new replacement.

**Q: Photos do not capture subject of interest**

1. Check the “PIR sensitivity” menu option. Set the “PIR sensitivity” to “High” to obtain the highest performance. At normal temperature of 77°F, “High” sensitivity for 75~100ft detecting distance, “Medium” for 50ft, “Low” for 30ft.
2. Try to set your camera up in an area where there is not a heat source in the camera’s view of sight.
3. In some cases, setting the camera near water will make the camera take images with no subject in them. Try aiming the camera over ground.
4. Try to avoid setting the camera up on small trees that are prone to being moved by strong winds.
5. Remove any limbs which are right in front of the camera lens.



6. Don't install the camera behind the window glass.

## EN **PART5: About Video Sound**

### **Q: The video is very clear, but the sound is not good**

The video has humming sound. The issue might be caused by strong wind, electromagnetic interference from electronic equipment, noise from cars, etc. Please try to install it at relative silent location to check if it becomes better.

If there is still a problem, please send a video of the problem to our customer support to request a solution.

## **PART6: About SD Card**

### **Q: There are problems with SD card access, such as not being recognized, the inability to delete photos,read/open photos or videos, etc.**

This trail camera supports full-size SD/SDHC/SDXC memory card. In general, for better performance we recommend using brand SD card, such as SanDisk, Kingston, Toshiba,Samsung, etc. When you first use the SD card with your camera, please format your SD card by using "Memory Card Format" menu option. Our experience indicates sometimes SD card might be in damaged or unstable condition, please replace SD card and try again. Or using SD card reader or computer slot, try to access it and check if the SD card does work.

If your SD card was ever formatted in NTFS format on your PC, it is not possible to be recognized by this camera, please

reformat your SD card in your camera by "Memory Card Format" menu option, restart the camera after the SD card formatted.

EN

## **PART7: About Camera Screen**

### **Q: When I turn on the camera, the screen just continually flashes white**

It may be due to poor batteries contact. It is recommended to remove the batteries, wipe both ends of the battery and the positive electrode ("flat") of the battery compartment and the spring with a clean cloth before reinstalling.

## **PART8: About Turn On**

### **Q: Camera won't power up**

1. Make sure that you have installed eight batteries in the battery compartment, filling battery all spaces with no "gaps". Make sure that the batteries are installed correctly, observing proper polarity. Always place the negative (flat) end of each battery in contact with the spring side of its slot inside the camera. Or install the batteries again to check if the camera can power up.
2. We recommend using new eight high quality 1.5V Alkaline or Lithium AA batteries. In some cases, the new batteries might be defective, even would be no power, it would be quite good if you have meter to measure the batteries voltage to double check.
3. 1.2V Rechargeable AA batteries are NOT recommended as

the lower voltage they produce can cause operational issues. The worst case is that some batteries might not be power the camera up.

EN

## **PART9: Other Issues**

### **Q: What if I forget my camera password?**

Turn off the camera, then press OK and UP keys hold while adjusting power switch to SET mode to unlock it.

### **Q: Why is there air in the trail camera? Is it a leak?**

The air inside the camera is currently at a normal humidity level. Temperature fluctuations can sometimes cause condensation, which will dissipate once the temperature stabilizes. Alternatively, you can accelerate the removal of condensation by using a desiccant.

### **Q: Can this Wi-Fi trail camera connect to more than one phone?**

Yes, this trail camera can connect to up to two smartphones simultaneously.

If your unit is still having trouble, please feel free to contact customer support with your order number. Please be assured we will make the things right for you.



## 14. WARRANTY

### **TWO-YEAR LIMITED WARRANTY**

**EN** Your KJK trail camera is backed by a two-year warranty starting from the date of original purchase. We assure you that your camera is designed to be free from defects in materials and workmanship when used under standard conditions. It's important to note that this warranty excludes damages resulting from misuse, abuse, improper handling or installation, damage caused by wildlife, or any unauthorized repair attempts.

During the warranty period, we reserve the right to either repair or replace your camera with an identical or similar model at no cost. Please be aware that this warranty is applicable exclusively to the original retail purchaser through our authorized dealer network. To avail of warranty benefits, you'll need to provide proof of the original purchase date, such as a purchase receipt or order number. Any replacement product issued under this warranty will be covered for the remaining duration of the original product's warranty period. This warranty specifically addresses failures attributed to material or workmanship defects during normal usage and does not extend to regular wear and tear.

If you require assistance with a warranty claim, kindly get in touch with your dealer or our authorized distributor.

## 15. FCC COMPLIANCE STATEMENT

This device complies with Part 15 of the FCC Rules. Operation is subject to the following conditions:

- (1) This device may not cause harmful interference
- (2) This device must accept any interference received, including interference that may cause undesired operation.

Please Note: This equipment has been tested and found to comply with the limits for a Class B digital device, pursuant to part 15 of the FCC Rules. These limits are designed to provide reasonable protection against harmful interference in a residential installation. This equipment generates uses and can radiate radio frequency energy and, if not installed and used in accordance with the instructions, may cause harmful interference to radio communications. However, there is no guarantee that interference will not occur in a particular installation. If this equipment does cause harmful interference to radio or television reception, which can be determined by turning the equipment off and on, the user is encouraged to try to correct the interference by one or more of the following measures:

EN

- Reorient or relocate the receiving antenna.
- Increase the separation between the equipment and the receiver.
- Connect the equipment into an outlet on a circuit different from that to which the receiver is connected.

**Caution: To comply with the limits for an FCC Class B computing device, always use the signal cord and power cord supplied with this unit.**

The Federal communications Commission warns that changes or modifications to the unit not expressly approved by the party responsible for compliance could void the user's authority to operate the equipment.



## Contact Us



support@kjkcam.com



@KJKcam



@KJKcam



@KJKcam